



## TECHNICAL APPLICATION FORM

This form helps HD Slippers Staff to offer and advise for the better sealing solution and can avoid misunderstanding and problems during seal installation and operation

Equipment/Application

Existing Application

New Application

### Reason for change in case of existing application

Feasibility

Lead Time

Technical Advice

Notes

### Motion

Static

Reciprocating

Oscillatory

Rotary

### Product type

Piston

Rod/Shaft

Internal Face

External Face

Wiper

Guiding Ring

Back-up Ring

### Operating parameters

minimum

operating

maximum

Temperature  
Pressure  
Stroke Length  
Circle Rate  
Speed



Media Approvals

Notes

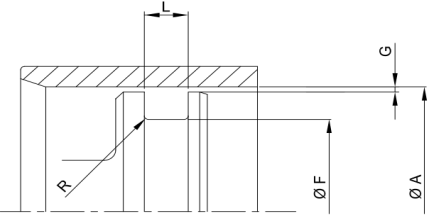
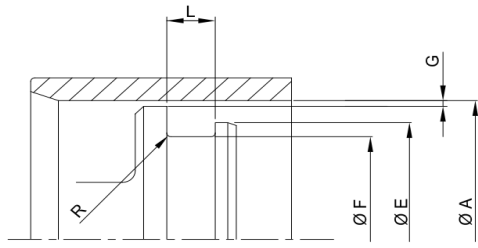
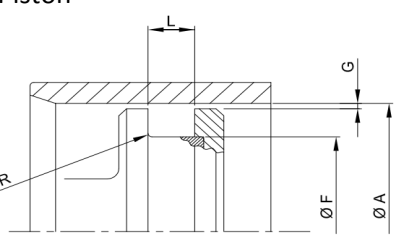
## Hardware specifications

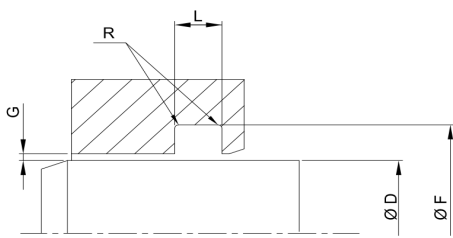
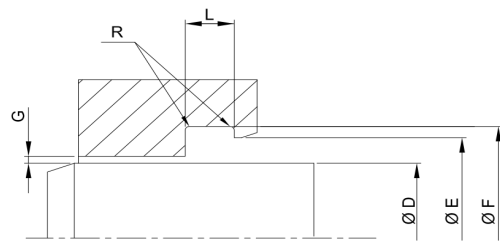
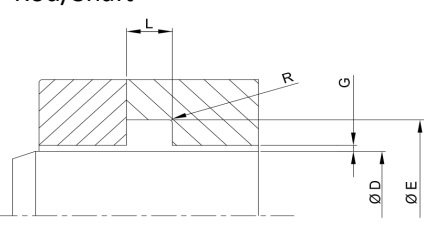
<p>Piston</p> 	<p>Piston</p> 
<p>Piston</p> 	<p> <math>\text{ØA}</math> [mm] _____ Dynamic surface  <math>\text{ØE}</math> [mm] _____ Material _____  <math>\text{ØF}</math> [mm] _____ Hardness _____  <math>R</math> [mm] _____ Finish _____  <math>G</math> [mm] _____  <math>L</math> [mm] _____         </p>

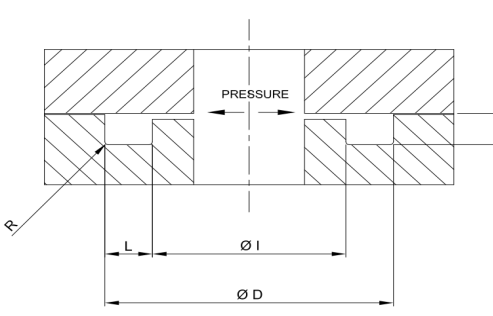
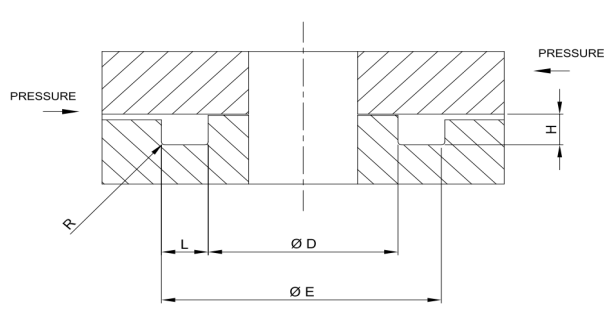
<p>Rod/Shaft</p> 	<p>Rod/Shaft</p> 
<p>Rod/Shaft</p> 	<p> <math>\text{ØD}</math> [mm] _____ Dynamic surface  <math>\text{ØE}</math> [mm] _____ Material _____  <math>\text{ØF}</math> [mm] _____ Hardness _____  <math>R</math> [mm] _____ Finish _____  <math>G</math> [mm] _____  <math>L</math> [mm] _____         </p>

<p>Face</p>  <p> <math>\text{ØD}</math> [mm] _____  <math>L</math> [mm] _____         </p>	<p>Face</p>  <p> <math>H</math> [mm] _____  <math>R</math> [mm] _____         </p>
---	--

**SPACE FOR FREE DRAW**

Please indicate or draw any hole/chamfer/groove  
that could obstruct installation

Notes